



### Selection: Open-Type Reciprocating Compressors

#### Input Values

Compressor model	4N.2Y-K	Useful superheat	100%
Refrigerant	R404A	Motor speed	1450 /min
Reference temperature	Dew point temp.	Drive	Coupling (1:1)
Liq. subc. (in condenser)	0 K	Capacity control	100%
Suction gas temperature	20,00 °C		

#### Result

Q [W]	Cooling capacity	COP [ - ]	COP/EER
Q* [W]	Cooling capacity *	COP* [ - ]	COP/EER *
P [kW]	Power input	m [kg/h]	Mass flow
Qc [W]	Condenser capacity	n [/min]	Compr. speed

tc	to	5°C	0°C	-5°C	-10°C	-15°C	-20°C	-25°C	-30°C
30°C	Q [W]	66441	55782	46531	38512	31578	25606	20488	16127
	Q* [W]	66441	55782	46531	38512	31578	25606	20488	16127
	P [kW]	11,38	11,18	10,80	10,28	9,64	8,90	8,09	7,25
	Qc [W]	77819	66961	57336	48794	41216	34505	28581	23376
	COP [ - ]	5,84	4,99	4,31	3,75	3,28	2,88	2,53	2,22
	COP* [ - ]	5,84	4,99	4,31	3,75	3,28	2,88	2,53	2,22
	m [kg/h]	1713	1418	1169	958	779	627	499	391
	n [/min]	1450	1450	1450	1450	1450	1450	1450	1450
40°C	Q [W]	57043	47861	39863	32907	26878	21674	17206	13395
	Q* [W]	57043	47861	39863	32907	26878	21674	17206	13395
	P [kW]	13,15	12,70	12,09	11,36	10,54	9,64	8,71	7,75
	Qc [W]	70195	60559	51956	44271	37416	31317	25912	21148
	COP [ - ]	4,34	3,77	3,30	2,90	2,55	2,25	1,98	1,73
	COP* [ - ]	4,34	3,77	3,30	2,90	2,55	2,25	1,98	1,73
	m [kg/h]	1663	1373	1128	921	745	596	470	364
	n [/min]	1450	1450	1450	1450	1450	1450	1450	1450
50°C	Q [W]	47495	39849	33148	27292	22194	17777	13972	10715
	Q* [W]	47495	39849	33148	27292	22194	17777	13972	10715
	P [kW]	15,05	14,36	13,54	12,62	11,63	10,60	9,55	8,51
	Qc [W]	62544	54205	46686	39913	33827	28378	23522	19223
	COP [ - ]	3,16	2,78	2,45	2,16	1,91	1,68	1,46	1,26
	COP* [ - ]	3,16	2,78	2,45	2,16	1,91	1,68	1,46	1,26
	m [kg/h]	1611	1327	1087	884	711	564	440	335
	n [/min]	1450	1450	1450	1450	1450	1450	1450	1450

-- No calculation possible (see message in single point selection)  
 \*According to EN12900 (20°C suction gas temp., 0K liquid subcooling)

### Application Limits Standard 4N.2

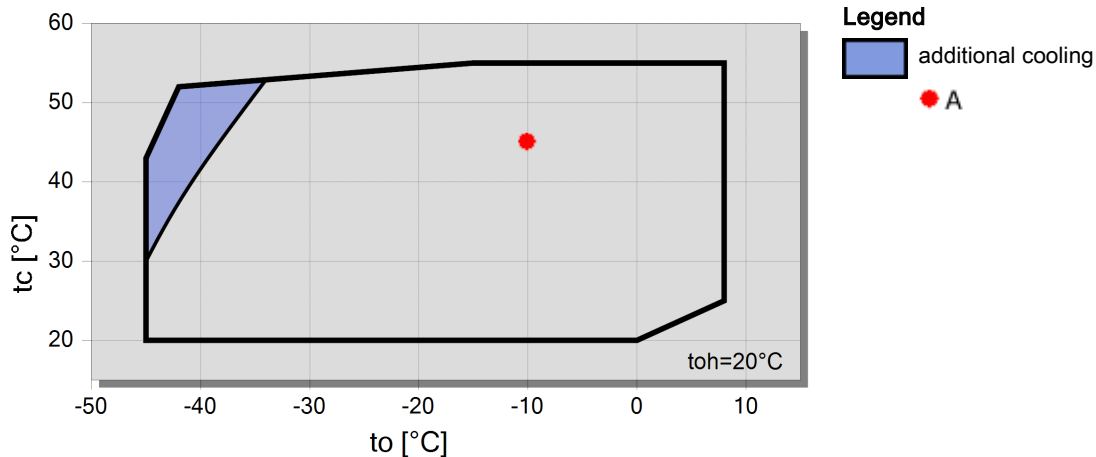



## Technical Data: 4N.2Y-K

### Dimensions and Connections

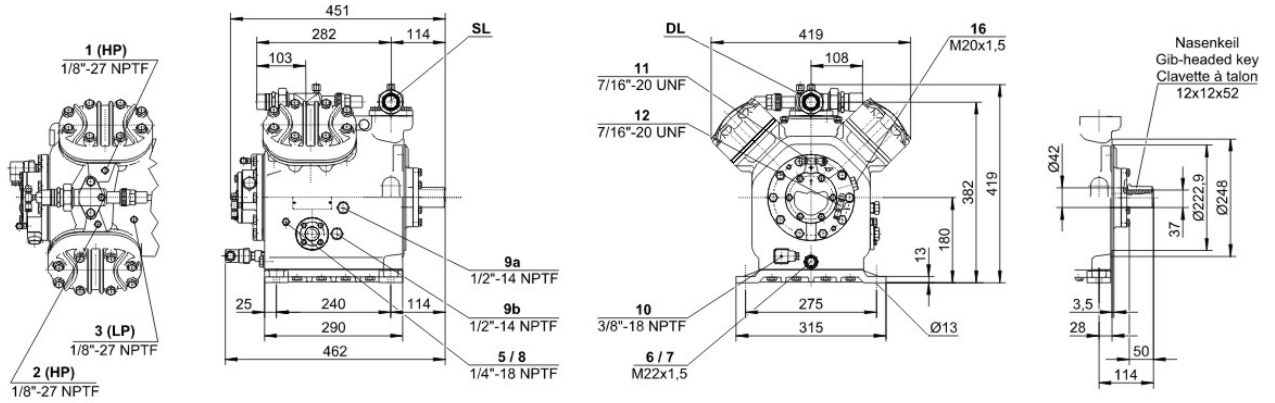



## Technical Data

### Technical Data

Displacement (1450 RPM 50Hz)	56,1 m <sup>3</sup> /h
Displacement (1750 RPM 60Hz)	67,7 m <sup>3</sup> /h
No. of cylinder x bore x stroke	4 x 60 mm x 57 mm
Allowed speed range	750 .. 1750 1/min
Weight	77 kg
Max. pressure (LP/HP)	19 / 25 bar
Connection suction line	35 mm - 1 3/8"
Connection discharge line	28 mm - 1 1/8"
Oil type R134a/R407C/R404A/R507A/R407A/R407F	tc<55°C: BSE32 / tc>55°C: BSE55 (Option)
Oil type R22 (R12/R502)	B5.2 (Standard)

### Extent of delivery (Standard)

Oil charge	4,0 dm <sup>3</sup>
Protective charge	Standard
Suction shut-off valve	Standard
Discharge shut-off valve	Standard

### Available Options

Coupling (...-K) w. A/C + medium	KK411 [<11kW] / KK420 [<22kW] (Option)
Coupling (...-K) w. low temp.	KK415 [<7.5kW] / KK425 [<22kW] (Option)
Coupling housing	Option
Motor pulley (...-S)	190, 210, 230 mm (Option)
V-belts	3 x SPA (Option)
Discharge gas temperature sensor	Option (incl. INT69VS)
Start unloading	Option
Connection cooling water	R 1/2" (Option)
Capacity control	100-50% (Option)
Additional fan	Option
Water-cooled cylinder heads	Option
Oil service valve	Option
Crankcase heater	100 W (Option)
Oil pressure monitoring	MP54 (Option)
Kit for marine application	Option



## Open-Type Reciprocating Compressors

### Motor Selection

The required driving motor is selected for starting conditions at direct start as well as at star-delta- or PW-start with start unloading (bypass + check valve). The starting conditions refer to the following defined operation points resp. to the maximum application limit of the compressor. Should the evaporation- or the condensing temperature of the plant be higher at the start, an individual motor selection is necessary.

Evaporation temperature for motor selection				
	HH	H	M	L
R134a	+20 °C	+12,5 °C	-5 °C	-20 °C
R404A / R507A		+7,5 °C	-5 °C	-20 °C
R407F / R407A				
R22		+12,5 °C	-5 °C	-20 °C
NH <sub>3</sub>	+15 °C	+10 °C	-5 °C	

The stated motor data refer to IEC motors at which the pull-up torque does not fall below 90% of the max. torque. In addition the following starting torques (referring to direct starting torque) must be reached:

- \* 2-cylinder compressors 220 %
- \* 4-cylinder compressors 180 %
- \* 6-cylinder compressors 160 %

Should the motor not fulfil these criteria, an individual selection is also necessary.

### Condenser capacity

The condenser capacity can be calculated with or without heat rejection. This option can be set in the menu Program  Options. The heat rejection is constantly 5% of the power consumption. The condensing capacity is to be found in the line cond.cap. (with HR) resp. cond.cap.

#### Legend of connection positions according to "Dimensions":

- 1 High pressure connection (HP)
- 2 Connection for discharge gas temperature sensor (HP) (for 4VE(S)-6Y .. 4NE(S)-20(Y) connection for CIC sensor as alternative)
- 3 Low pressure connection (LP)
- 4 CIC system: injection nozzle (LP)
- 4b Connection for CIC sensor
- 4c Connection for CIC sensor (MP / operation with liquid subcooler)
- 5 Oil fill plug
- 6 Oil drain
- 7 Oil filter (magnetic screw)
- 8 Oil return (oil separator)
- 8\* Oil return with NH<sub>3</sub> and insoluble oil
- 9 Connection for oil and gas equalization (parallel operation)
- 9a Connection for gas equalization (parallel operation)
- 9b Connection for oil equalization (parallel operation)
- 10 Oil heater connection
- 11 Oil pressure connection +
- 12 Oil pressure connection -
- 13 Cooling water connection
- 14 Intermediate pressure connection (MP)
- 15 Liquid injection (operation without liquid subcooler and with thermostatic expansion valve)
- 16 Connection for oil monitoring (opto-electrical oil monitoring "OLC-K1" or differential oil pressure switch "Delta-PII")
- 17 Refrigerant inlet at liquid subcooler
- 18 Refrigerant outlet at liquid subcooler
- 19 Clamp space
- 20 Terminal plate
- 21 Maintenance connection for oil valve
- 22 Pressure relief valve to the atmosphere (discharge side)
- 23 Pressure relief valve to the atmosphere (suction side)
- SL Suction gas line



DL Discharge gas line

Dimensions can show tolerances according to EN ISO 13920-B.